

Neptune
MIXER COMPANY



***Portable
Mixers***



Introduction / Mixer Selection

Portable Mixers from Neptune Mixer Company

Neptune mixers have been designed, engineered and built to provide long life and trouble-free service in a wide variety of blending/mixing operations. These mixers are popularly used to:

1. Blend liquids.
2. Suspend or dissolve solids
3. Disperse immiscible liquids
4. Disperse small amounts of gases in liquids

Neptune portable mixers can be clamp- or base-mounted on beams, tank walls or other supports. Angle of entry may be adjusted to meet specific mixing requirements.

Neptune portable mixers find use in a variety of different industrial applications...waste treatment, water treatment and batch chemical preparation. These portables are also ideal for mixing paints, varnishes, polymers, textile sizes and dyes, pharmaceuticals, soaps and countless other materials from 1 to over 25,000 CPS viscosity.

In the following pages, we present specifications, dimensions and dimensional drawings and other information to help you select the proper Neptune mixer for your application, depending on

the size of the batch, the viscosity of the components and final product, and other parameters. Our portables are available at either 350 or 420 RPM (gear-driven) or 1750 RPM (direct-drive).

If you have any questions or wish to discuss your mixing/blending application with us, please feel free to call one of our sales engineers.

Neptune Mixer Selection Chart

The chart below is intended to provide some basic guidelines for selecting the proper Neptune mixer(s) to provide mild blending of various viscosity liquids in different size tanks.

This chart is based on an approximate mix/blend time for two liquids of 30 minutes, with both liquids already in the tank. Mixing times will be shortened if one liquid is added to a second liquid while the mixer is operating. Powders should always be added while the mixer is running.

This chart also applies to the suspension of solids with settling velocities of less than one foot per minute.

For more rapid or vigorous mixing, use a mixer one or two sizes larger.

Dual propellers are recommended for tanks 1000 gallons and larger at viscosities of 1000 CPS and higher.

VISCOSITY CPS	UP TO 50 Gallons	UP TO 100 Gallons	UP TO 200 Gallons	UP TO 500 Gallons	UP TO 1000 Gallons	UP TO 2000 Gallons	UP TO 3000 Gallons	UP TO 5000 Gallons
≤ 1	BN-3.0	BN-3.0	JD-2.0	JD-2.0	JG-2.0	JG-2.0	JG-2.0	JG-4.0
≤ 100	BN-3.0	BN-3.0	JD-2.0	JG-2.0	JG-2.0	JG-2.0	JG-3.0	JG-5.0
≤ 300	BN-3.0	BN-3.0	JG-2.0	JG-2.0	JG-2.0	JG-4.0	JG-5.0	JG-5.0
≤ 500	BN-3.0	JG-2.0	JG-2.0	JG-2.0	JG-3.0	JG-5.0	JG-6.0	JG-7.0
≤ 1000	JD-2.0	JG-2.0	JG-2.0	JG-2.0	JG-4.0	JG-6.0	JG-7.0	JG-8.0
≤ 2000	JG-2.0	JG-2.0	JG-3.0	JG-3.0	JG-5.0	JG-6.0	JG-8.0	JG-9.0
≤ 3000	JG-2.0	JG-2.0	JG-4.0	JG-4.0	JG-6.0	JG-8.0	JG-9.0	
≤ 5000	JG-2.0	JG-2.0	JG-5.0	JG-5.0	JG-7.0	JG-8.0		
≤ 15000	JG-3.0	JG-3.0	JG-5.0	JG-8.0	JG-9.0	JG-9.0		
≤ 25000	JG-6.0	JG-7.0	JG-8.0	JG-9.0				

For full specifications and information on the above mixers:

Series JG – see page 4

Series JD – see page 8

Series BN – see page 10

The Neptune Guarantee: If the mixer we select does not produce the desired process results, we will replace it with a mixer that will.



Proper Mixer Mounting and Positioning

In most applications involving small mixing tanks of 1000 gallons or less, the mixer is clamped to the side of the tank. Optimum mixing will be achieved when the mixer is angled from the tank wall, either off center (figure 1) or on center (figure 2). Improperly mounting a portable mixer will greatly lessen mixing efficiency, cause vibration and could possibly damage the mixer.

Angling off center is preferred when good material turnover is required, as in mixing a slurry. Angling on center is desired for more gentle mixing and when vortexing must be minimized.

Larger size tanks may require that a mixer be mounted directly in the center of the tank with the shaft vertical (figure 3). When a mixer is used in this arrangement, baffles are recommended to prevent the contents of the tank from turning in the direction of the mix. If this occurs, mixing action will be poor.

Such baffling will avoid vortexing and allow mixing to be as thorough as possible. Neptune suggests that four baffles be used, located 90° apart and sized approximately 1/12 of the tank diameter. The baffle should not fully extend to the bottom of the tank and a gap should be provided between the baffle and the tank wall.

For assistance in choosing a mixer or to help solve your mixing problems, please call or Fax one of our sales engineers: 215-699-8700, Fax 800-255-4017.

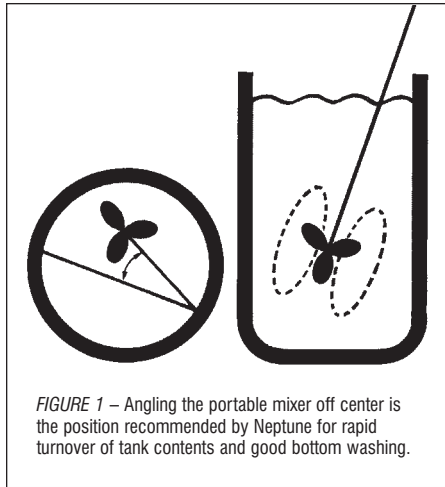

FIGURE 1 – Angling the portable mixer off center is the position recommended by Neptune for rapid turnover of tank contents and good bottom washing.

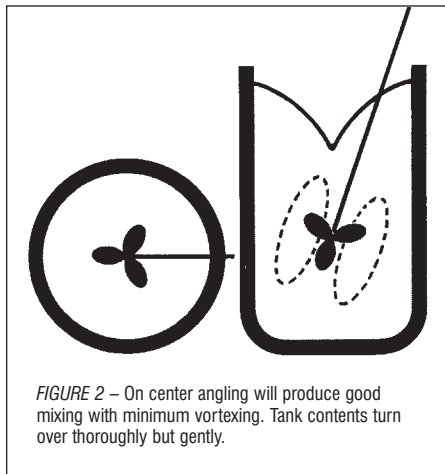

FIGURE 2 – On center angling will produce good mixing with minimum vortexing. Tank contents turn over thoroughly but gently.

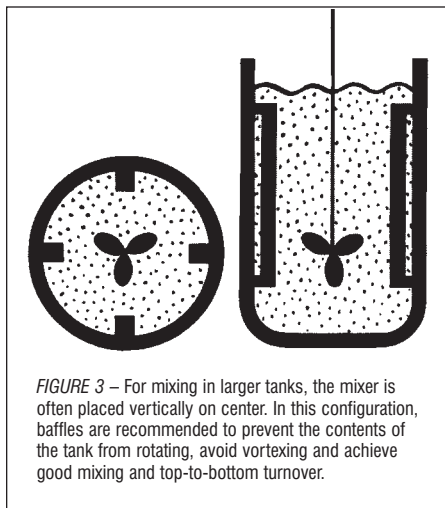

FIGURE 3 – For mixing in larger tanks, the mixer is often placed vertically on center. In this configuration, baffles are recommended to prevent the contents of the tank from rotating, avoid vortexing and achieve good mixing and top-to-bottom turnover.

Contents

Page

Gear Drive

Series JG – Clamp Mount 350 RPM, 1/3 through 3 HP	4
Series JGR – Angle-Riser Mount 350 RPM, 1/3 through 5 HP	5
Series JGF – Flange Mount 350 RPM, 1/3 through 5 HP	6
Series D – Clamp Mount 420 RPM, 1/3 through 1½ HP	7

Direct Drive

Series JD – Clamp Mount 1750 RPM, 1/3 through 2 HP	8
Series C – Clamp Mount 1750 RPM, 1/2 through 1½ HP	9

Small Clamp Mount & Laboratory Mixers

Series BN, batch mixers, 1750 RPM	10
Series L, laboratory mixers	10
Series A and B, economy mixers, 1750 RPM	11
Series BC, 1 and 2 HP air mixers	11

Drum & Tote Mixers

Bung-entering mixers – 55 gallon drum Series E, F, H and HGS	12 & 13
Flange mount air mixers – Series BF, 1 HP through 3 HP	13
Tote and Semi-Bulk container mixers and Brackets Series HGL, DT, RAB and RGT	14 & 15

Specialty Mixers

Pipe and Pail-Mount, Hand-Held	Back Cover
---	------------

Series JG

Gear Drive Mixer, Clamp or Cup Plate Mount

Heavy Helical Gear, 350 rpm, Grease Lube

Neptune's most powerful mixers for the most difficult mixing applications. Grease filled gearbox eliminates oil seal and the possibility of oil contamination of process.

Features

- No clutches to slip, wear or replace.
- 316SS propellers and shafts are standard. Optional coatings such as rubber, PVC or Teflon® also available.
- Square pitch 1.0 ratio marine propellers are used exclusively. Flow coefficients and power consumption characteristics equal those of the best hydrofoil impeller designs.
- Vibration-absorbing pad standard.
- Motors are available in TEFC or explosion-proof enclosures (1750 rpm, 56C frame). Air motors also available.
- Gears run in grease lubrication. Cannot leak oil.
- All JG mixer shaft bearings are permanently lubricated.
- Variable speed drives also available.
- Cast aluminum housing.
- Mounting clamp has adjustable angle of entry by indexed ball-and-socket design to achieve various process results.
- Fixed cup plate mount optional on 1/3 HP through 1 1/2 HP. Standard on 2 HP and larger models.

Model Number	Standard Motor Description	A Shaft Length	B	C		D Shaft Diameter
				Single	Dual	
Totally-enclosed fan-cooled (TEFC)						
JG-2.0	1/3 HP-1-115/230	48"	17 1/8"	10"	8"	3/4"
JG-2.1	1/3 HP-3-230/460	48"	17 1/8"	10"	8"	3/4"
JG-3.0	1/2 HP-1-115/230	48"	18 1/2"	12"	10"	3/4"
JG-3.1	1/2 HP-3-230/460	48"	17 1/8"	12"	10"	3/4"
JG-4.0	3/4 HP-1-115/230	60"	18 3/4"	13"	11"	3/4"
JG-4.1	3/4 HP-3-230/460	60"	18 1/8"	13"	11"	3/4"
JG-5.1	1 HP-3-230/460	60"	18 3/8"	14"	12"	1"
JG-6.1	1 1/2 HP-3-230/460	60"	18 3/4"	15"	13"	1"
JG-7.1	2 HP-3-230/460	60"	20 3/8"	16"	14"	1 1/4"
JG-8.1	3 HP-3-230/460	72"	21 3/8"	16"	15"	1 1/4"
Explosion-proof class 1 group D (EP)						
JG-2.2	1/3 HP-1-115/230	48"	20 1/2"	10"	8"	3/4"
JG-2.3	1/3 HP-3-230/460	48"	17 3/8"	10"	8"	3/4"
JG-3.2	1/2 HP-1-115/230	48"	21"	12"	10"	3/4"
JG-3.3	1/2 HP-3-230/460	48"	19 3/4"	12"	10"	3/4"
JG-4.2	3/4 HP-1-115/230	60"	21 1/2"	13"	11"	3/4"
JG-4.3	3/4 HP-3-230/460	60"	19 3/8"	13"	11"	3/4"
JG-5.3	1 HP-3-230/460	60"	20 1/2"	14"	12"	1"
JG-6.3	1 1/2 HP-3-230/460	60"	20 1/2"	15"	13"	1"
JG-7.3	2 HP-3-230/460	60"	22 1/8"	16"	14"	1 1/4"
Air motor						
JG-3.4	1/3 HP to 1/2 HP AIR Air Requirements: 12-20CFM at 40-80PSI	48"	17 1/8"	12"	10"	3/4"
JG-4.4	3/4 HP AIR Air Requirements: 30CFM at 60PSI	60"	18"	13"	11"	3/4"
JG-5.4	1 HP AIR Air Requirements: 40CFM at 40PSI	60"	19 1/8"	14"	12"	1"
JG-6.4	1 1/2 HP AIR Air Requirements: 55CFM at 60PSI	60"	19 3/4"	15"	13"	1"
JG-7.4	2 HP AIR Air Requirements: 65CFM at 70PSI	60"	15 3/8"	16"	14"	1 1/4"
JG-8.4	4 HP AIR Air Requirements: 125CFM at 90PSI	72"	16 3/4"	16"	15"	1 1/4"

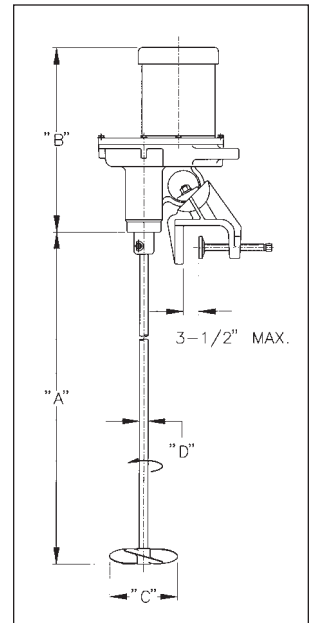
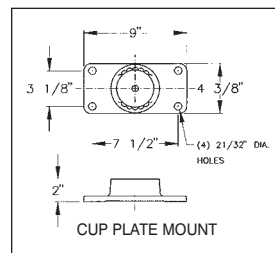
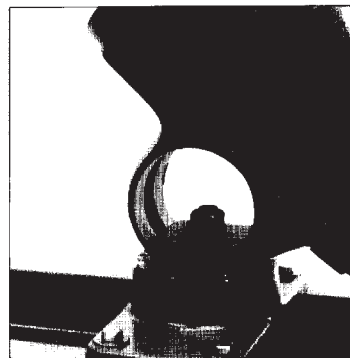
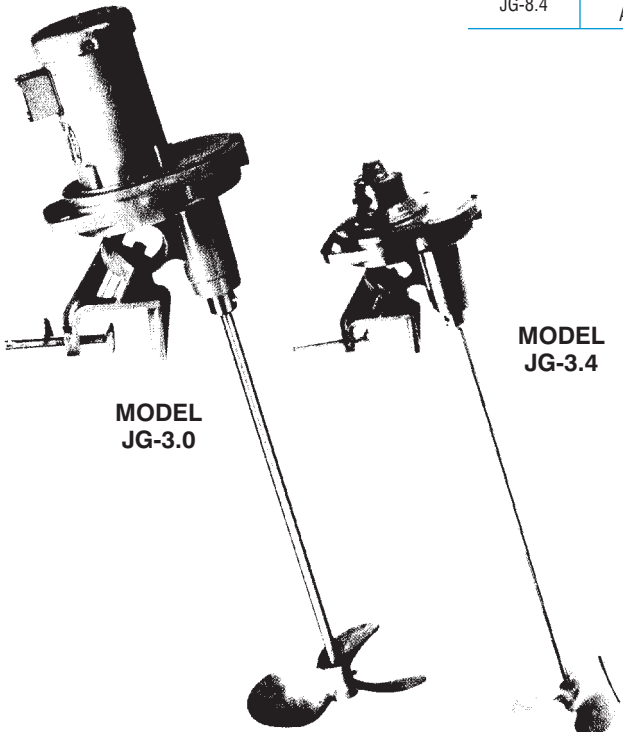

Series JGR

Gear Drive Mixer, Angle-Riser Mount

Heavy Helical Gear, 350 rpm, Grease Lube

Features

- No clutches to slip, wear or replace.
- 316SS propellers and shafts are standard. Optional coatings such as rubber, PVC or Teflon® also available.
- Square pitch 1.0 ratio marine propellers are used exclusively. Flow coefficients and power consumption characteristics equal those of the best hydrofoil impeller designs.
- Vibration-absorbing pad standard.
- Motors are available in TEFC or explosion-proof enclosures (1750 rpm, 56C frame). Air motors also available.
- Gears run in grease lubrication. Cannot leak oil.
- All JGR mixer shaft bearings are permanently lubricated.
- Variable speed drives also available.
- Cast aluminum housing.
- Angle-riser mount provides a fixed 10° angle of entry.



**MODEL
JGR-8.1**

Model Number	Standard Motor Description	A Shaft Length	B	C		D Shaft Diameter
				Single	Dual	
Totally-enclosed fan-cooled (TEFC)						
JGR-2.0	1/3 HP-1-115/230	48"	17½"	10"	8"	¾"
JGR-2.1	1/3 HP-3-230/460	48"	17½"	10"	8"	¾"
JGR-3.0	1/2 HP-1-115/230	48"	18½"	12"	10"	¾"
JGR-3.1	1/2 HP-3-230/460	48"	17½"	12"	10"	¾"
JGR-4.0	3/4 HP-1-115/230	60"	18¾"	13"	11"	¾"
JGR-4.1	3/4 HP-3-230/460	60"	18½"	13"	11"	¾"
JGR-5.1	1 HP-3-230/460	60"	18¾"	14"	12"	1"
JGR-6.1	1½ HP-3-230/460	60"	18¾"	15"	13"	1"
JGR-7.1	2 HP-3-230/460	60"	20¾"	16"	14"	1½"
JGR-8.1	3 HP-3-230/460	72"	21¾"	16"	15"	1½"
JGR-9.1	5 HP-3-230/460	72"	23"	16"	15"	1½"
Explosion-proof class 1 group D (EP)						
JGR-2.2	1/3 HP-1-115/230	48"	20½"	10"	8"	¾"
JGR-2.3	1/3 HP-3-230/460	48"	17¾"	10"	8"	¾"
JGR-3.2	1/2 HP-1-115/230	48"	21"	12"	10"	¾"
JGR-3.3	1/2 HP-3-230/460	48"	19¾"	12"	10"	¾"
JGR-4.2	3/4 HP-1-115/230	60"	21½"	13"	11"	¾"
JGR-4.3	3/4 HP-3-230/460	60"	19¾"	13"	11"	¾"
JGR-5.3	1 HP-3-230/460	60"	20½"	14"	12"	1"
JGR-6.3	1½ HP-3-230/460	60"	20½"	15"	13"	1"
JGR-7.3	2 HP-3-230/460	60"	22¾"	16"	14"	1½"
Air motor						
JGR-3.4	1/3 HP to 1/2 HP AIR Air Requirements: 12-20CFM at 40-80PSI	48"	17½"	12"	10"	¾"
JGR-4.4	3/4 HP AIR Air Requirements: 30CFM at 60PSI	60"	18"	13"	11"	¾"
JGR-5.4	1 HP AIR Air Requirements: 40CFM at 40PSI	60"	19¾"	14"	12"	1"
JGR-6.4	1½ HP AIR Air Requirements: 55CFM at 60PSI	60"	19¾"	15"	13"	1"
JGR-7.4	2 HP AIR Air Requirements: 65CFM at 70PSI	60"	15¾"	16"	14"	1½"
JGR-8.4	4 HP AIR Air Requirements: 125CFM at 90PSI	72"	16¾"	16"	15"	1½"

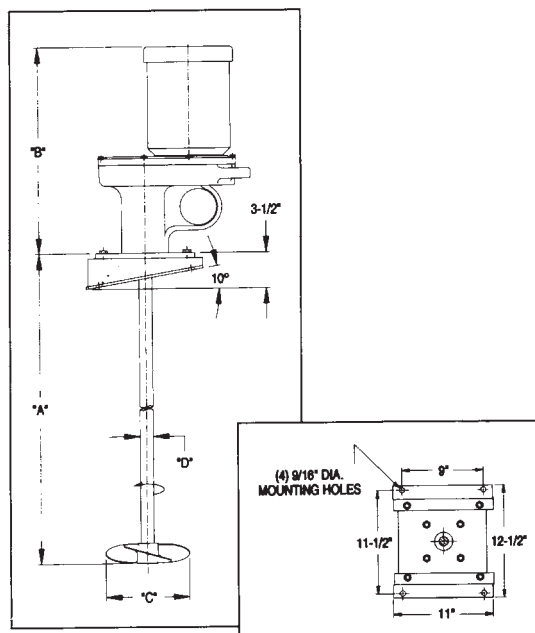

Series JGF

Gear Drive Mixer, Flange Mount

Heavy Helical Gear, 350 rpm, Grease Lube

Compact mixers for the most popular mixing applications. Grease filled gear-box eliminates oil seal and the possibility of oil contamination of process.

Features

- No clutches to slip, wear or replace.
- 316SS propellers and shafts are standard. Optional coatings such as rubber, PVC or Teflon® also available.
- Square pitch 1.0 ratio marine propellers are used exclusively. Flow coefficients and power consumption characteristics equal those of the best hydrofoil impeller designs.
- Vibration-absorbing pad standard.
- Motors are available in TEFC or explosion-proof enclosures (1750 rpm, 56C frame). Air motors also available.
- Gears run in grease lubrication. Cannot leak oil.
- All JGF mixer shaft bearings are permanently lubricated.
- Variable speed drives also available.
- Cast aluminum housing.
- Flange stuffing box rated to 15 PSI.
- Standard mounting flange is 6" carbon steel, 316SS optional.
- Optional flanges available in 8", 10", 12" or 14".

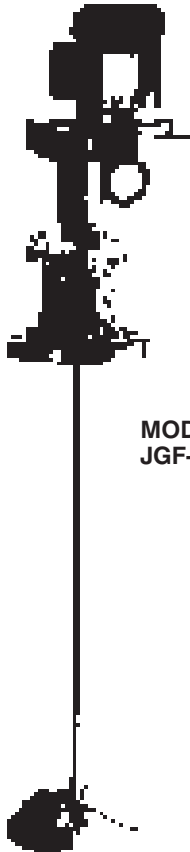

MODEL JGF-8.1

Model Number	Standard Motor Description	A Shaft Length	B	C		D Shaft Diameter
				Single	Dual	
Totally-enclosed fan-cooled (TEFC)						
JGF-2.0	1/3 HP-1-115/230	48"	17 $\frac{1}{2}$ "	10"	8"	$\frac{3}{4}$ "
JGF-2.1	1/3 HP-3-230/460	48"	17 $\frac{3}{8}$ "	10"	8"	$\frac{3}{4}$ "
JGF-3.0	1/2 HP-1-115/230	48"	18 $\frac{1}{2}$ "	12"	10"	$\frac{3}{4}$ "
JGF-3.1	1/2 HP-3-230/460	48"	17 $\frac{3}{8}$ "	12"	10"	$\frac{3}{4}$ "
JGF-4.0	3/4 HP-1-115/230	60"	18 $\frac{3}{4}$ "	13"	11"	$\frac{3}{4}$ "
JGF-4.1	3/4 HP-3-230/460	60"	18 $\frac{1}{2}$ "	13"	11"	$\frac{3}{4}$ "
JGF-5.1	1 HP-3-230/460	60"	18 $\frac{3}{8}$ "	14"	12"	1"
JGF-6.1	1 $\frac{1}{2}$ HP-3-230/460	60"	18 $\frac{3}{4}$ "	15"	13"	1"
JGF-7.1	2 HP-3-230/460	60"	20 $\frac{3}{8}$ "	16"	14"	1 $\frac{1}{4}$ "
JGF-8.1	3 HP-3-230/460	72"	21 $\frac{1}{2}$ "	16"	15"	1 $\frac{1}{4}$ "
JGF-9.1	5 HP-3-230/460	72"	23"	16"	15"	1 $\frac{1}{4}$ "
Explosion-proof class 1 group D (EP)						
JGF-2.2	1/3 HP-1-115/230	48"	20 $\frac{1}{2}$ "	10"	8"	$\frac{3}{4}$ "
JGF-2.3	1/3 HP-3-230/460	48"	17 $\frac{3}{8}$ "	10"	8"	$\frac{3}{4}$ "
JGF-3.2	1/2 HP-1-115/230	48"	21"	12"	10"	$\frac{3}{4}$ "
JGF-3.3	1/2 HP-3-230/460	48"	19 $\frac{1}{2}$ "	12"	10"	$\frac{3}{4}$ "
JGF-4.2	3/4 HP-1-115/230	60"	21 $\frac{1}{2}$ "	13"	11"	$\frac{3}{4}$ "
JGF-4.3	3/4 HP-3-230/460	60"	19 $\frac{1}{2}$ "	13"	11"	$\frac{3}{4}$ "
JGF-5.3	1 HP-3-230/460	60"	20 $\frac{1}{2}$ "	14"	12"	1"
JGF-6.3	1 $\frac{1}{2}$ HP-3-230/460	60"	20 $\frac{1}{2}$ "	15"	13"	1"
JGF-7.3	2 HP-3-230/460	60"	22 $\frac{1}{4}$ "	16"	14"	1 $\frac{1}{4}$ "
Air motor						
JGF-3.4	1/3 HP to 1/2 HP AIR Air Requirements: 12-20CFM at 40-80PSI	48"	17 $\frac{1}{2}$ "	12"	10"	$\frac{3}{4}$ "
JGF-4.4	3/4 HP AIR Air Requirements: 30CFM at 60PSI	60"	18"	13"	11"	$\frac{3}{4}$ "
JGF-5.4	1 HP AIR Air Requirements: 40CFM at 40PSI	60"	19 $\frac{1}{2}$ "	14"	12"	1"
JGF-6.4	1 $\frac{1}{2}$ HP AIR Air Requirements: 55CFM at 60PSI	60"	19 $\frac{1}{2}$ "	15"	13"	1"
JGF-7.4	2 HP AIR Air Requirements: 65CFM at 70PSI	60"	15 $\frac{3}{8}$ "	16"	14"	1 $\frac{1}{4}$ "
JGF-8.4	4 HP AIR Air Requirements: 125CFM at 90PSI	72"	16 $\frac{3}{4}$ "	16"	15"	1 $\frac{1}{4}$ "

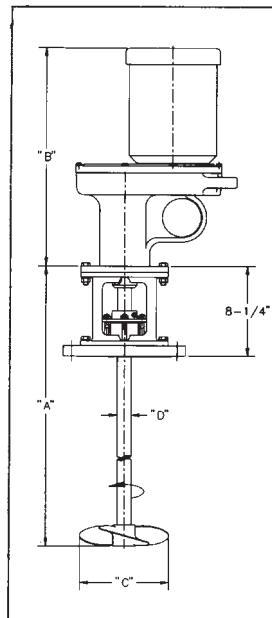

Series D

Gear Drive Mixer, Clamp Mount

Planetary Gear, 420 rpm, Grease Lube

Neptune's original line of gear-driven mixers for mixing heavy fluids and slurries or large batches of thin liquids.

Features

- Motors are available in TEFC or explosion-proof enclosures (1750 rpm, 56C frame). Air motors also available.
- Universal indexing clamp allows most efficient mixer positioning.
- Fixed cup plate mount optional.
- Square pitch 1.0 ratio marine propellers are used exclusively. Flow coefficients and power consumption characteristics equal those of the best hydrofoil impeller designs.
- 316SS propellers and shafts are standard. Optional coatings such as rubber, PVC or Teflon® also available.
- No clutches to slip, wear or replace.
- Vibration-absorbing pad standard.
- Gears run in grease, giving quiet operation.
- Bearings are permanently lubricated for quiet operation and extended life.
- Cast aluminum housing.
- Variable speed drives also available.

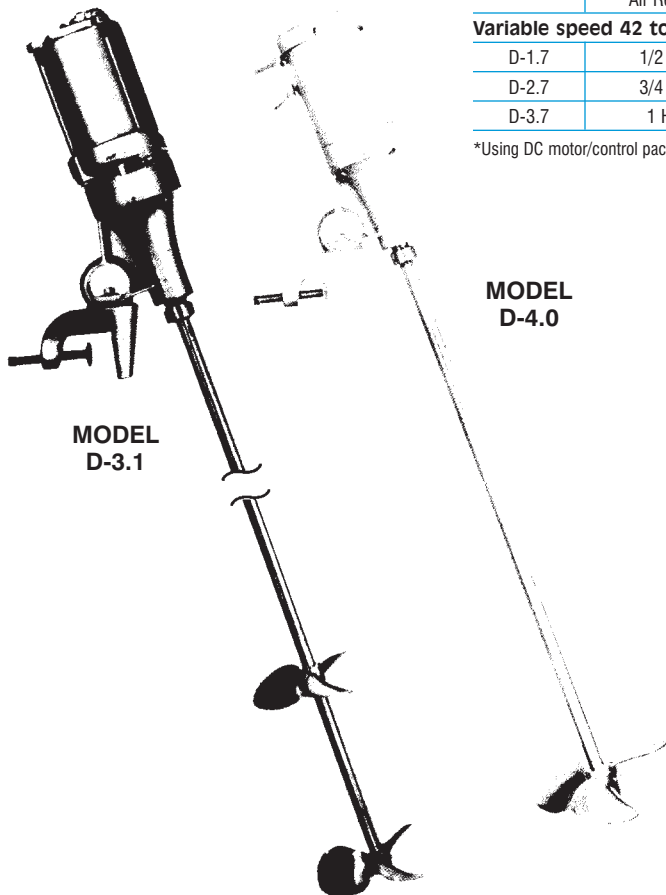

MODEL D-4.0

MODEL D-3.1

Model Number	Standard Motor Description	A Shaft Length	B	C		D Shaft Diameter
				Single	Dual	
Totally-enclosed fan-cooled (TEFC)						
D-0.0	1/3 HP-1-115/230	48"	20 7/8"	6"	6"	1"
D-0.2	1/3 HP-3-230/460	48"	20 7/8"	6"	6"	1"
D-1.0	1/2 HP-1-115/230	48"	20 7/8"	11"	10"	1"
D-1.2	1/2 HP-3-230/460	48"	19 1/4"	11"	10"	1"
D-2.0	3/4 HP-1-115/230	60"	20 7/8"	12"	11"	1"
D-2.2	3/4 HP-3-230/460	60"	20 7/8"	12"	11"	1"
D-3.0	1 HP-3-230/460	60"	20 7/8"	13"	11"	1 1/4"
D-4.0	1 1/2 HP-3-230/460	60"	20 7/8"	14"	12"	1 1/4"
Explosion-proof class 1 group D (EP)						
D-0.1	1/3 HP-1-115/230	48"	20 7/8"	6"	6"	1"
D-0.3	1/3 HP-3-230/460	48"	20 7/8"	6"	6"	1"
D-1.1	1/2 HP-1-115/230	48"	22 7/8"	11"	10"	1"
D-1.3	1/2 HP-3-230/460	48"	20 3/4"	11"	10"	1"
D-2.1	3/4 HP-1-115/230	60"	23 7/8"	12"	11"	1"
D-2.3	3/4 HP-3-230/460	60"	20 7/8"	12"	11"	1"
D-3.1	1 HP-3-230/460	60"	24 1/2"	13"	11"	1 1/4"
D-4.1	1 1/2 HP-3-230/460	60"	21 1/2"	14"	12"	1 1/4"
Air motor						
D-0.4	1/3 HP AIR Air Requirements: 20CFM at 40PSI	48"	20 7/8"	6"	6"	1"
D-1.4	1/2 HP AIR Air Requirements: 20CFM at 40PSI	48"	16 7/8"	11"	10"	1"
D-2.4	3/4 HP AIR Air Requirements: 30CFM at 60PSI	60"	16 7/8"	12"	11"	1"
D-3.2	1 HP AIR Air Requirements: 40CFM at 40PSI	60"	17 3/4"	13"	11"	1 1/4"
D-4.2	1 1/2 HP AIR Air Requirements: 55CFM at 60PSI	60"	17 3/4"	14"	12"	1 1/4"
Variable speed 42 to 420 RPM totally-enclosed non-ventilated (TENV)*						
D-1.7	1/2 HP Variable Speed, 1/115 V	48"	20 7/8"	11"	10"	1"
D-2.7	3/4 HP Variable Speed, 1/230 V	60"	20 7/8"	12"	11"	1"
D-3.7	1 HP Variable Speed, 1/230 V	60"	20 7/8"	13"	11"	1 1/4"

*Using DC motor/control package.

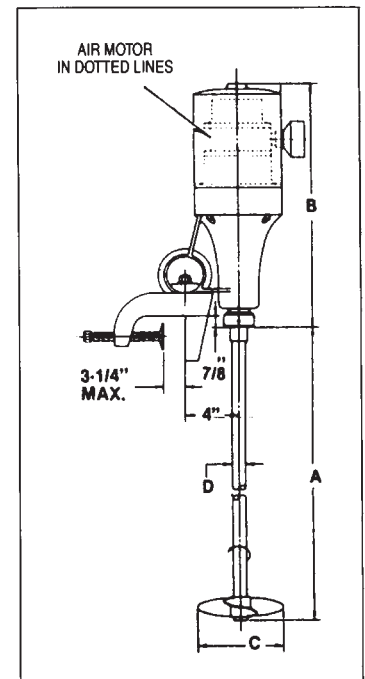
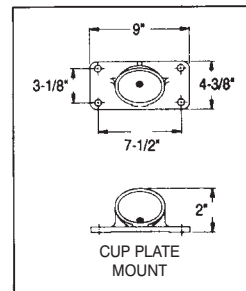

Series JD

Direct Drive Mixer, Clamp or Cup Plate Mount

1750 rpm, Grease Lube

This mixer was engineered to meet the need for a large direct drive mixer with a housing that cannot leak oil.

Features

- Square pitch 1.0 ratio marine propellers are used exclusively. Flow coefficients and power consumption characteristics equal those of the best hydrofoil impeller designs.
- 316SS propellers and shafts are standard. Optional coatings such as rubber, PVC or Teflon® also available.
- JD mixers have adjustable angles of entry by indexed ball-and-socket design to achieve different process results.
- Motors are available in TEFC or explosion-proof enclosures (1750 rpm, 56C frame). Air motors also available.
- Vibration-absorbing pad standard.
- All JD mixer shaft bearings are permanently lubricated.
- Variable speed drives also available.
- Cast aluminum housing.
- Fixed cup plate mount optional.

Model Number	Standard Motor Description	A Shaft Length	B	C		D Shaft Diameter
				Single	Dual	
Totally-enclosed fan-cooled (TEFC)						
JD-2.0	1/3 HP-1-115/230	36"	21 $\frac{1}{8}$ "	4"	4"	$\frac{3}{4}$ "
JD-2.1	1/3 HP-3-230/460	36"	20 $\frac{3}{4}$ "	4"	4"	$\frac{3}{4}$ "
JD-3.0	1/2 HP-1-115/230	48"	22"	5"	4"	$\frac{3}{4}$ "
JD-3.1	1/2 HP-3-230/460	48"	21 $\frac{1}{2}$ "	5"	4"	$\frac{3}{4}$ "
JD-4.0	3/4 HP-1-115/230	48"	22 $\frac{1}{4}$ "	5"	4"	$\frac{3}{4}$ "
JD-4.1	3/4 HP-3-230/460	48"	21 $\frac{1}{2}$ "	5"	4"	$\frac{3}{4}$ "
JD-5.1	1 HP-3-230/460	60"	21 $\frac{3}{4}$ "	6"	5"	1"
JD-6.1	1 $\frac{1}{2}$ HP-3-230/460	60"	22 $\frac{1}{4}$ "	6"	5"	1"
JD-7.1	2 HP-3-230/460	60"	23 $\frac{1}{2}$ "	7"	6"	1"
Explosion-proof class 1 group D (EP)						
JD-2.2	1/3 HP-1-115/230	36"	24"	4"	4"	$\frac{3}{4}$ "
JD-2.3	1/3 HP-3-230/460	36"	20 $\frac{3}{4}$ "	4"	4"	$\frac{3}{4}$ "
JD-3.2	1/2 HP-1-115/230	48"	24 $\frac{1}{2}$ "	5"	4"	$\frac{3}{4}$ "
JD-3.3	1/2 HP-3-230/460	48"	23 $\frac{1}{8}$ "	5"	4"	$\frac{3}{4}$ "
JD-4.2	3/4 HP-1-115/230	48"	25"	5"	4"	$\frac{3}{4}$ "
JD-4.3	3/4 HP-3-230/460	48"	23 $\frac{1}{2}$ "	5"	4"	$\frac{3}{4}$ "
JD-5.3	1 HP-3-230/460	60"	24"	6"	5"	1"
JD-6.3	1 $\frac{1}{2}$ HP-3-230/460	60"	24"	6"	5"	1"
JD-7.3	2 HP-3-230/460	60"	25 $\frac{1}{2}$ "	7"	6"	1"
Air motor						
JD-3.4	1/3 HP to 1/2 HP AIR Air Requirements: 12-20CFM at 20-40PSI	48"	16 $\frac{1}{2}$ "	5"	4"	$\frac{3}{4}$ "
JD-4.4	3/4 HP AIR Air Requirements: 30CFM at 60PSI	48"	17 $\frac{3}{8}$ "	5"	4"	$\frac{3}{4}$ "
JD-5.4	1 HP AIR Air Requirements: 40CFM at 40PSI	60"	18 $\frac{1}{2}$ "	6"	5"	1"
JD-6.4	1 $\frac{1}{2}$ HP AIR Air Requirements: 55CFM at 60PSI	60"	18 $\frac{1}{2}$ "	6"	5"	1"
JD-7.4	2 HP AIR Air Requirements: 65CFM at 75PSI	60"	18 $\frac{1}{2}$ "	7"	6"	1"

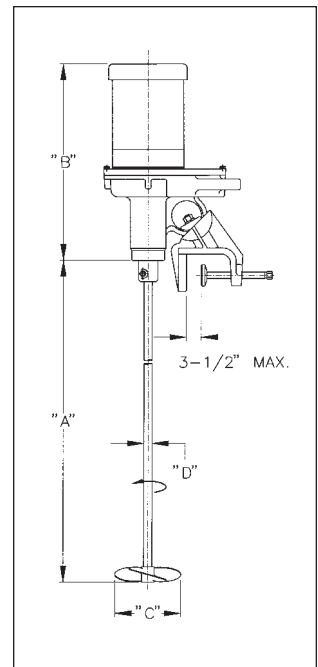
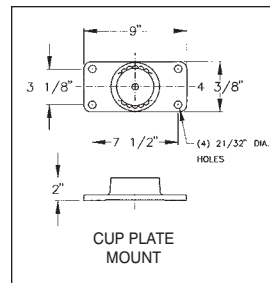
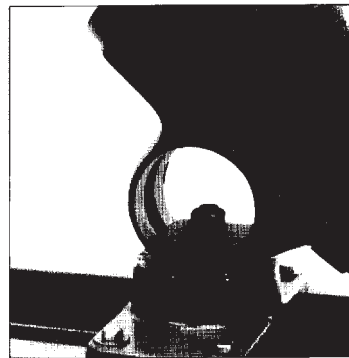
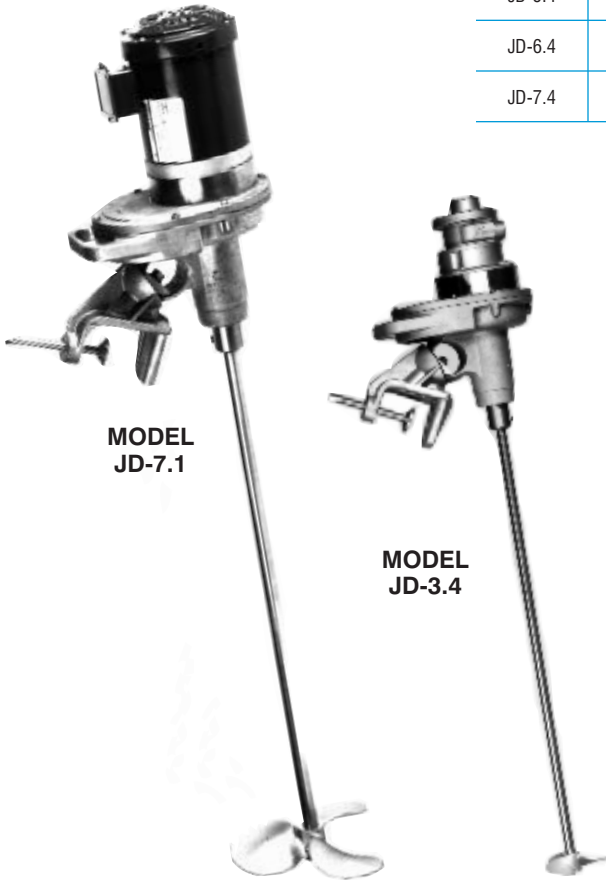

Series C

Direct Drive Mixer, Clamp Mount

1750 rpm, Grease Lube

Neptune's original line of large, direct drive, portable mixers for mixing larger batches of light and medium solutions or small batches of heavy fluids.

Features

- Motors are available in TEFC or explosion-proof enclosures (1750 rpm, 56C frame). Air motors also available.
- Universal indexing clamp allows most efficient mixer positioning.
- Fixed cup plate mount optional.
- Square pitch 1.0 ratio marine propellers are used exclusively. Flow coefficients and power consumption characteristics equal those of the best hydrofoil impeller designs.
- 316SS propellers and shafts are standard. Optional coatings such as rubber, PVC or Teflon® also available.
- Vibration-absorbing pad standard.
- Cast aluminum housing.
- Gears run in grease, giving quiet operation.
- Bearings run in grease for quiet operation and extended life.
- Variable speed drives also available.

Model Number	Standard Motor Description	A Shaft Length	B	C		D Shaft Diameter
				Single	Dual	
Totally-enclosed fan-cooled (TEFC)						
C-1.0	1/2 HP-1-115/230	48"	22 $\frac{7}{8}$ "	5"	4"	$\frac{3}{4}$ "
C-1.2	1/2 HP-3-230/460	48"	19 $\frac{1}{4}$ "	5"	4"	$\frac{3}{4}$ "
C-2.0	3/4 HP-1-115/230	48"	20 $\frac{1}{2}$ "	5"	4"	$\frac{3}{4}$ "
C-2.2	3/4 HP-3-230/460	48"	20 $\frac{1}{2}$ "	5"	4"	$\frac{3}{4}$ "
C-3.0	1 HP-3-230/460	60"	20 $\frac{1}{2}$ "	6"	5"	$\frac{3}{4}$ "
C-4.0	1 $\frac{1}{2}$ HP-3-230/460	60"	20 $\frac{1}{2}$ "	6"	5"	1"
Explosion-proof class 1 group D (EP)						
C-1.1	1/2 HP-1-115/230	48"	22 $\frac{7}{8}$ "	5"	4"	$\frac{3}{4}$ "
C-1.3	1/2 HP-3-230/460	48"	20 $\frac{1}{4}$ "	5"	4"	$\frac{3}{4}$ "
C-2.1	3/4 HP-1-115/230	48"	23 $\frac{7}{8}$ "	5"	4"	$\frac{3}{4}$ "
C-2.3	3/4 HP-3-230/460	48"	20 $\frac{1}{2}$ "	5"	4"	$\frac{3}{4}$ "
C-3.1	1 HP-3-230/460	60"	24 $\frac{1}{2}$ "	6"	5"	$\frac{3}{4}$ "
C-4.1	1 $\frac{1}{2}$ HP-3-230/460	60"	21 $\frac{1}{2}$ "	6"	5"	1"
Air motor						
C-1.6	1/2 HP AIR Air Requirements: 20CFM at 40PSI	48"	16 $\frac{1}{2}$ "	5"	4"	$\frac{3}{4}$ "
C-2.6	3/4 HP AIR Air Requirements: 30CFM at 60PSI	48"	16 $\frac{1}{2}$ "	5"	4"	$\frac{3}{4}$ "
C-3.4	1 HP AIR Air Requirements: 40CFM at 40PSI	60"	17 $\frac{1}{4}$ "	6"	5"	$\frac{3}{4}$ "
C-4.2	1 $\frac{1}{2}$ HP AIR Air Requirements: 55CFM at 60PSI	60"	17 $\frac{1}{4}$ "	6"	5"	1"
Variable speed 175 to 1725 RPM totally-enclosed non-ventilated (TENV)*						
C-1.7	1/2 HP Variable Speed, 1/115 V	48"	20 $\frac{1}{2}$ "	5"	4"	$\frac{3}{4}$ "
C-2.7	3/4 HP Variable Speed, 1/230 V	48"	20 $\frac{1}{2}$ "	5"	4"	$\frac{3}{4}$ "
C-3.7	1 HP Variable Speed, 1/230 V	60"	20 $\frac{1}{2}$ "	6"	5"	$\frac{3}{4}$ "

*Using DC motor/control package.

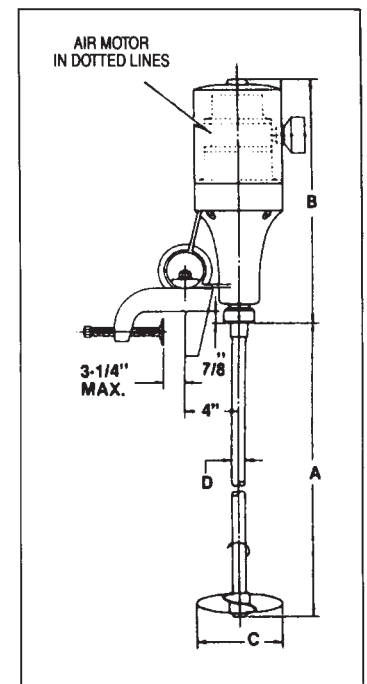
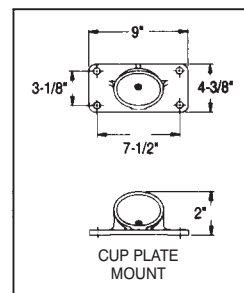
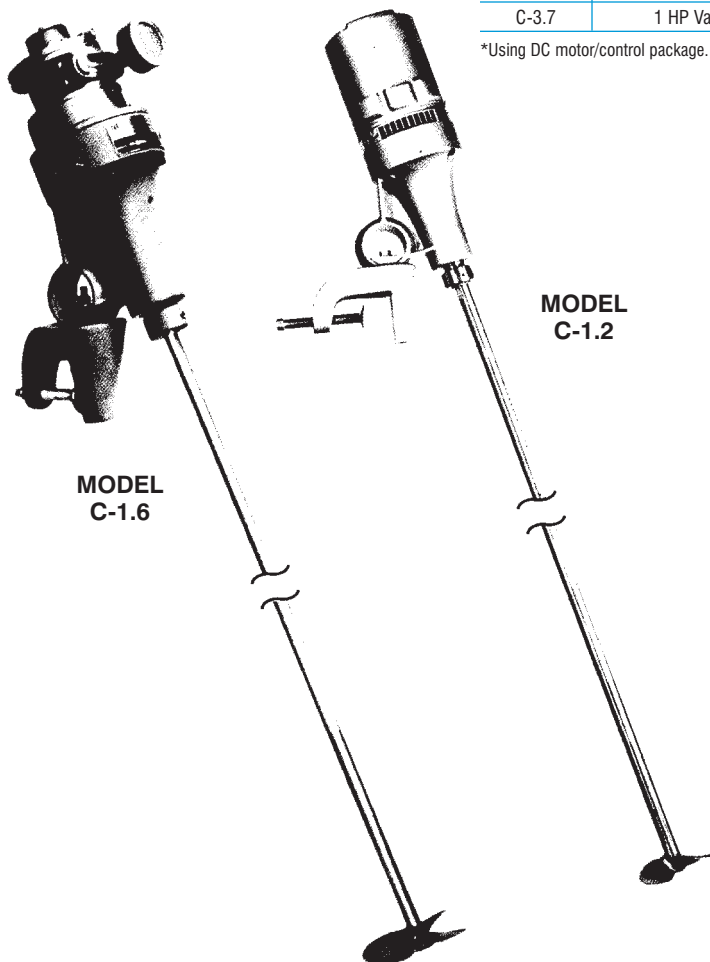

Series BN

Small Batch Mixer, 1750 rpm

Direct Drive, Clamp Mount

Neptune's premier line of small direct drive mixers for mixing small batches of low viscosity fluids.

Features

- Mounting ease. Clamp cannot slip, preventing propeller from hitting side of tank.
- Quick, easy adjustment between "angled-on-center" and "angled-off-center" positions without tools.
- Coupling is fully enclosed.
- Motors are available in TEFC or explosion-proof enclosures (56C frame). Air motors also available.
- Off-the-shelf delivery.
- Standard shaft and prop materials:
 - 316SS
 - Carpenter 20
- Clamp adjusts to any angle.

Model Number	Standard Motor Description	Shaft Length	Shaft Diameter
Totally-enclosed fan-cooled (TEFC)			
BN-1.0	1/4 HP-1-115/230	32"	1/2"
BN-2.0	1/3 HP-1-115/230	32"	1/2"
BN-2.2	1/3 HP-3-230/460	32"	1/2"
BN-3.0	1/2 HP-1-115/230	32"	5/8"
BN-3.2	1/2 HP-3-230/460	32"	5/8"
Explosion-proof class 1 group D (EP)			
BN-2.1	1/3 HP-1-115/230	32"	1/2"
BN-2.3	1/3 HP-3-230/460	32"	1/2"
BN-3.1	1/2 HP-1-115/230	32"	5/8"
BN-3.3	1/2 HP-3-230/460	32"	5/8"
Air motor			
BN-4.0	1/4 HP to 1/2 HP AIR	32"	5/8"

To develop 1/4 HP at 1725 RPM requires 10 CFM at 15 PSI;
 1/3 HP at 1725 RPM requires 12 CFM at 20 PSI;
 1/2 HP at 1725 RPM requires 22 CFM at 40 PSI.

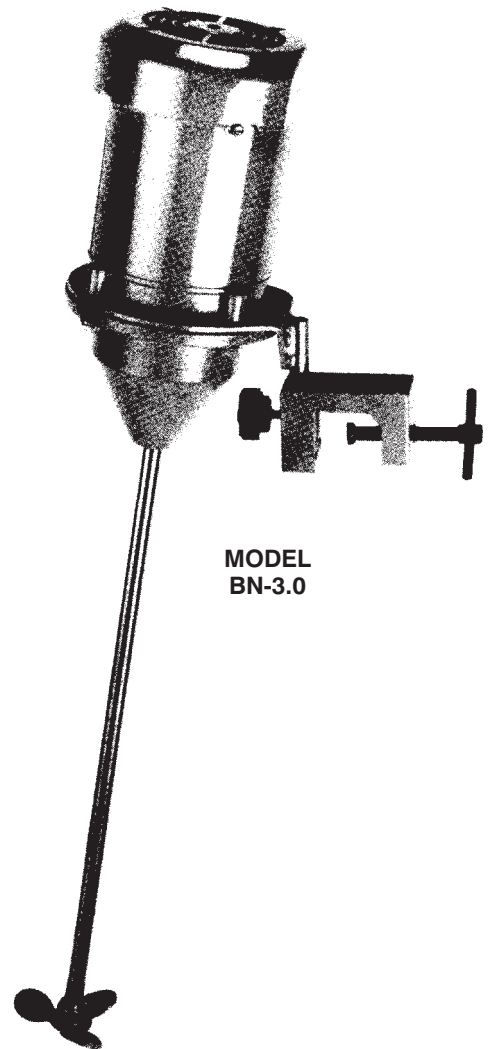
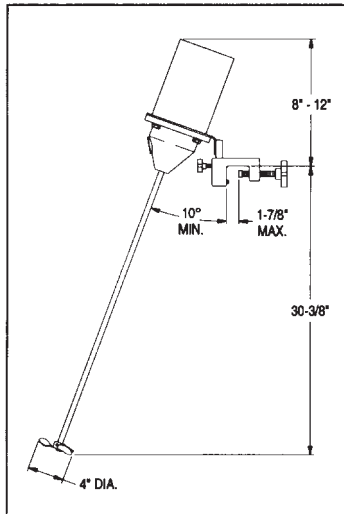

MODEL BN-3.0

Series L

Laboratory Mixers

Bar, Clamp and Bracket Mount

Neptune's Laboratory Mixers are available in air or electric drive with clamp or bracket mount. The air motors include a control valve and muffler.

Model L-1-AC includes a C-clamp and the air supply pipe passes through the C-clamp. Model L-1-A does not include a C-clamp but the air supply pipe will fit a standard one-half-inch laboratory bar clamp.

Cord and plug are standard with 1550 rpm electric models. Operating speed ranges from 200 to 2000 rpm with air motors.

Model Number	Standard Motor Description	Mount Type	RPM	Shaft Length	Prop. Diameter	Shaft Diameter
Totally-enclosed fan-cooled (TEFC)						
L-1-CL	1/20 HP-115-60	"C" Clamp	1550	30"	3"	5/16"
L-1-CL 24	1/20 HP-115-60	"C" Clamp	1550	24"	3"	5/16"
L-1-CL 18	1/20 HP-115-60	"C" Clamp	1550	18"	3"	5/16"
L-1-BK	1/20 HP-115-60	Bracket	1550	30"	3"	5/16"
Air motor						
L-1-A	*HP Air Motor	Lab Clamp	Variable	20"	3"	5/16"
L-1-AC	*HP Air Motor	"C" Clamp	Variable	20"	3"	5/16"

Air (speed) control valve included on air motor models

* Develops 0.10 HP @ 2000 RPM Requires 6 CFM @ 60 PSI
 0.175 HP @ 2000 RPM Requires 10 CFM @ 60 PSI

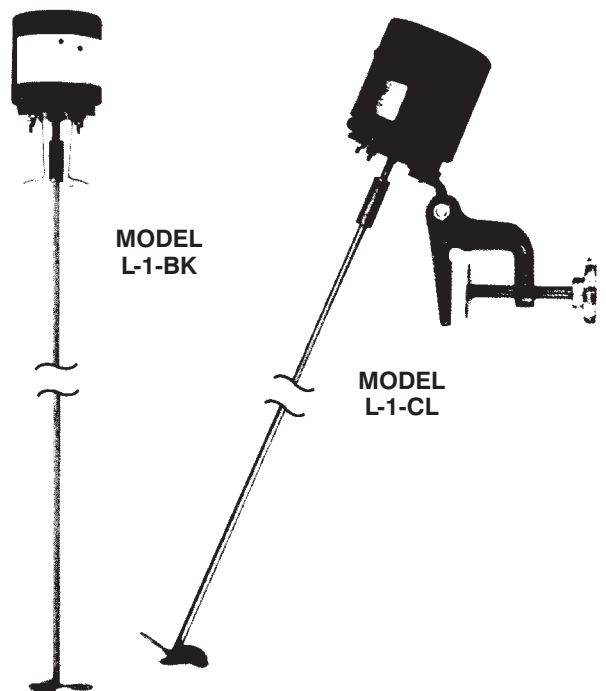

MODEL L-1-BK

MODEL L-1-CL

Series A and B Economy Batch Mixer, 1750 rpm Direct Drive Clamp Mount

Neptune's economy line of small direct drive mixers for small batches of low viscosity fluids.

Features

- Universal motor mount accepts 48 and 56 frame foot mounted motors.
- Motors are available in TEFC or explosion-proof enclosures. Air motors also available.
- Off-the-shelf delivery.
- Standard shaft and prop materials:
 - 316SS
- Clamp adjusts to any angle.

Model Number	Standard Motor Description	Shaft Length	Shaft Diameter
Totally-enclosed fan-cooled (TEFC)			
A-1.0	1/4 HP-1-115	32"	1/2"
B-1.0	1/4 HP-1-115/230	32"	1/2"
B-2.0	1/3 HP-1-115/230	32"	1/2"
B-3.0	1/2 HP-1-115/230	32"	5/8"
B-3.2	1/2 HP-3-230/460	32"	5/8"
Explosion-proof class 1 group D (EP)			
B-3.1	1/2 HP-1-115/230	32"	5/8"
Air motor			
B-4.0	1/4 HP to 1/2 HP AIR	35"	5/8"

To develop

- 1/4 HP at 1725 RPM requires 10 CFM at 45 PSI;
- 1/3 HP at 1725 RPM requires 14 CFM at 60 PSI;
- 1/2 HP at 1725 RPM requires 18 CFM at 80 PSI.

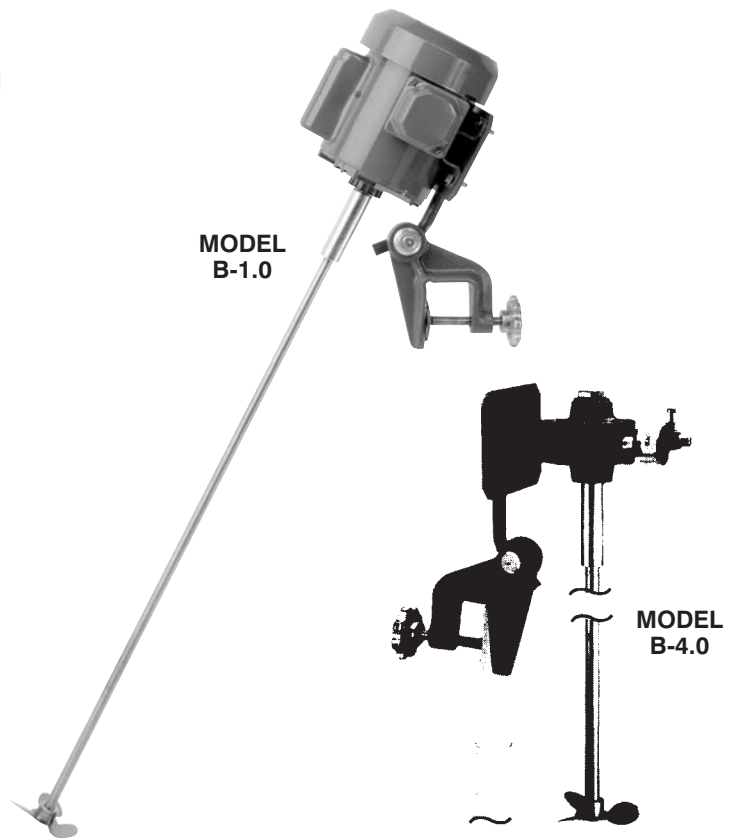

Laboratory-type
Air Mixer
MODEL L-1-AC
with C-clamp as shown

Series BC Direct Drive Air Mixer Clamp Mount

Neptune's clamp mounted, air driven mixer uses 316SS shaft and 316SS marine propellers.

Knob allows clamp to be loosened without tools to adjust shaft angle. Handle allows firm grip on mixer when positioning. Three blade left-hand marine propellers pump downward in normal operation. Air control valve included to allow speed adjustment. Motor may be stalled without damage.

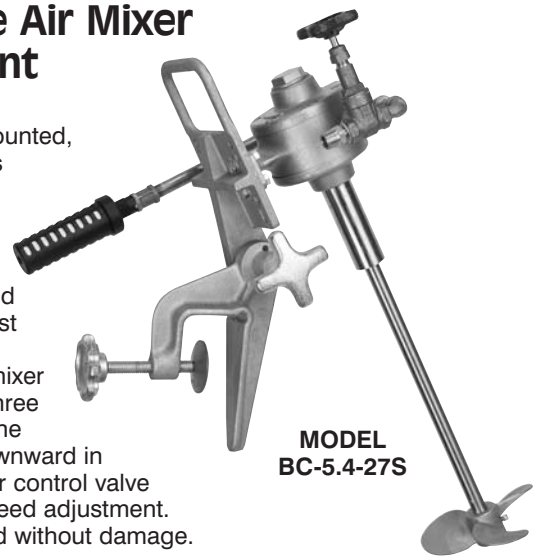

MODEL BC-5.4-27S

Model Number	Motor Horsepower	Shaft		Propeller Size	
		Diameter	Length	Single	Dual*
BC-5.4-27S	1 HP Air Motor	5/8"	27"	6"	6"
BC-5.4-36S	1 HP Air Motor	5/8"	36"	6"	6"
BC-5.4-48S	1 HP Air Motor	5/8"	48"	6"	6"
BC-7.4-27S	2 HP Air Motor	3/4"	27"	8"	N/A
BC-7.4-36S	2 HP Air Motor	3/4"	36"	8"	8"
BC-7.4-48S	2 HP Air Motor	3/4"	48"	8"	8"
BC-7.4-60S	2 HP Air Motor	3/4"	60"	8"	8"

Air set not included. Order P/N 100804 for complete air set consisting of regulator, filter and lubricator.

* To specify dual props: change "S" in Model Number to "D".

Air Consumption: 1 HP – 16 CFM at 70 PSI;
2 HP – 20 CFM at 70 PSI.

Drum Mixers

Bung-Entering – 55 Gallon Drum, 1750 rpm

Neptune Mixer Company offers a complete line of Bung-Entering Mixers. Two styles for water-like solutions use a folding propeller. Two styles (Series H & HGS) for viscous fluids use permanent blades and are offered in higher horse-powers. All Neptune Bung-Entering Mixers fit through the standard 2-in. Bung on 55-gallon drums.

Features

- Shaft and folding propeller are 316SS. Propeller folds for entry; opens to 3¾-in. diameter when operating.
- All mixers are in stock for off-the-shelf delivery.
- Motors are available in TEFC or explosion-proof enclosures (56C frame). Air motors also available.

CLOSED
(for entering)



OPEN
(for mixing)

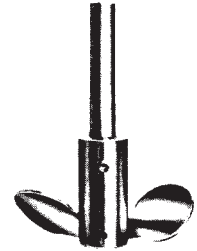

Series E Mixers

Model Number	Standard Motor Description	A
Totally-enclosed fan-cooled (TEFC)		
E-1.0	1/4 HP-1-115/230	13"
E-2.0	1/3 HP-1-115/230	13½"
E-2.2	1/3 HP-3-230/460	13½"
E-3.0	1/2 HP-1-115/230	14"
E-3.2	1/2 HP-3-230/460	13½"
Explosion-proof class 1 group D (EP)		
E-2.1	1/3 HP-1-115/230	14½"
E-2.3	1/3 HP-3-230/460	14½"
E-3.1	1/2 HP-1-115/230	16½"
E-3.3	1/2 HP-3-230/460	14½"
Air motor		
E-4.0	1/4 HP to 1/2 HP AIR Air Requirements: 10-20CFM at 20-40PSI	10½"

50 Hz Motors Available

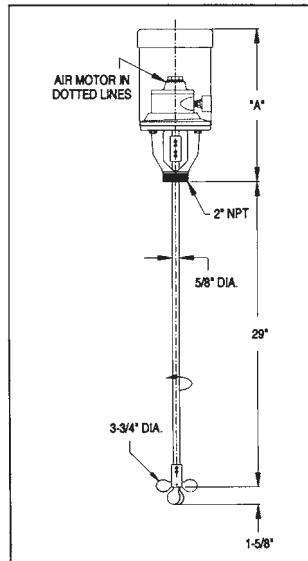

MODEL E-2.1
Screws into standard
2-in. bung fitting.



Series F Mixers

Model Number	Standard Motor Description	B
Totally-enclosed fan-cooled (TEFC)		
F-1.0	1/4 HP-1-115/230	10½"
F-2.0	1/3 HP-1-115/230	10½"
F-3.0	1/2 HP-1-115/230	11½"
F-3.2	1/2 HP-3-230/460	11½"
Explosion-proof class 1 group D (EP)		
F-3.1	1/2 HP-1-115/230	14½"
Air motor		
F-4.0	1/4 HP to 1/2 HP AIR Air Requirements: 10-20CFM at 40-80PSI	5½"

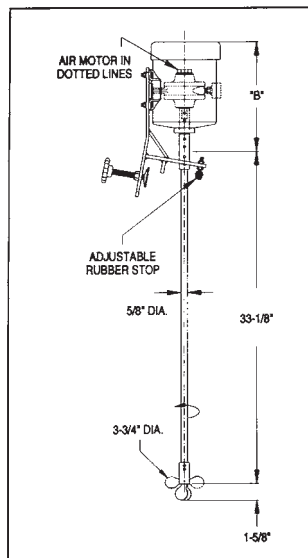

MODEL F-2.0
Clamps to lip of
standard steel drums.



Drum Mixers

Bung-Entering – 55 Gallon Drum, High Viscosity

Series H Mixers
 Direct Drive, 1750 rpm
 Viscosity to 8,000 CPS

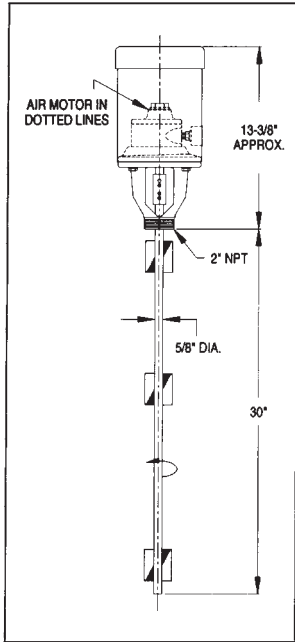

Six mixing blades.

Series HGS Mixers
 Gear Drive, 430 rpm
 Viscosity to 32,000 CPS

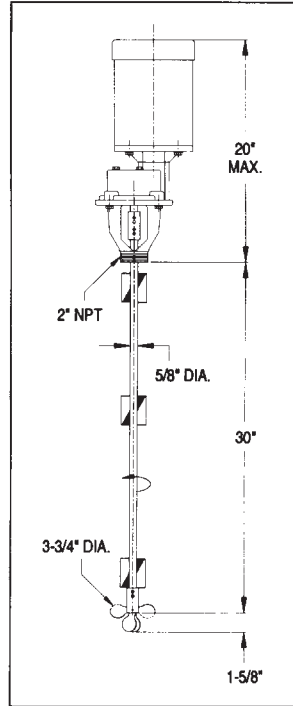

Six mixing blades with folding propeller.

Features

- Shaft and propeller are 316SS.
- Available electric or air motor powered to 1 HP.
- For mixing extremely heavy or shear sensitive chemicals in drums.
- Designed to screw into standard 2-in. bung opening on 55-gallon drums.

	SERIES H – DIRECT DRIVE		SERIES HGS – GEAR DRIVE	
Standard Motor Description	Model Number	Viscosity Limitation CPS	Model Number	Viscosity Limitation CPS
Totally-enclosed fan-cooled (TEFC)				
1/3 HP-1-115/230	H-2.0	1000	HGS-2.0	4000
1/2 HP-1-115/230	H-3.0	4000	HGS-3.0	16000
3/4 HP-1-115/230	H-5.0	6000	HGS-5.0	24000
1 HP-1-115/230	H-6.0	8000	HGS-6.0	32000
Air motor				
1/4 HP to 1/2 HP AIR Air Requirements: 10-20CFM at 20-40PSI	H-4.0	4000	HGS-4.0	24000
3/4 HP to 1 HP AIR Air Requirements: 30-40CFM at 25-35PSI	H-7.0	8000	HGS-7.0	32000

Explosion-proof models available—contact factory.

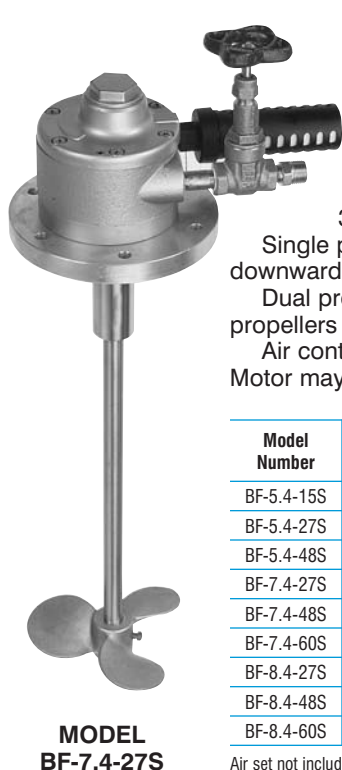
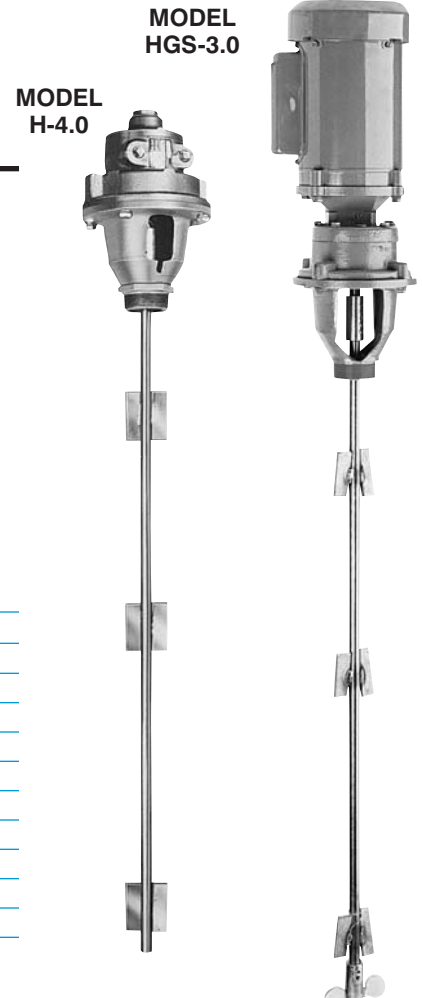

MODEL BF-7.4-27S

Series BF

Direct Drive Air Mixer

Flange Mount

Neptune's flange mounted, air driven mixer uses 316SS shaft and 316SS marine propellers.
 Single propeller models have one left-handed propeller pumping downward in normal operation.
 Dual propeller models have one each left-hand and right-hand propellers providing counterflow mixing.
 Air control valve included to allow speed adjustment.
 Motor may be stalled without damage.

Model Number	Motor Horsepower	Mounting Flange	Shaft		Propeller Size	
			Diameter	Length	Single	Dual*
BF-5.4-15S	1 HP Air Motor	6"	5/8"	15"	6"	6"
BF-5.4-27S	1 HP Air Motor	6"	5/8"	27"	6"	6"
BF-5.4-48S	1 HP Air Motor	6"	5/8"	48"	6"	6"
BF-7.4-27S	2 HP Air Motor	7"	3/4"	27"	8"	8"
BF-7.4-48S	2 HP Air Motor	7"	3/4"	48"	8"	8"
BF-7.4-60S	2 HP Air Motor	7"	3/4"	60"	8"	8"
BF-8.4-27S	3 HP Air Motor	7"	1"	27"	10"	10"
BF-8.4-48S	3 HP Air Motor	7"	1"	48"	10"	10"
BF-8.4-60S	3 HP Air Motor	7"	1"	60"	10"	10"

Air set not included. Order P/N 100804 for complete air set consisting of regulator, filter and lubricator.

* To specify dual props: change "S" in Model Number to "D".

Air Consumption: 1 HP – 16 CFM at 70 PSI; 2 HP – 20 CFM at 70 PSI; 3 HP – 30 CFM at 70 PSI.

Bulk Container Mixers – Gear Drive Bung or Bracket Mount Vertical Motors for Single Containers

Neptune Bulk Container Mixers allow mixing in semi-bulk shipping containers.

Series HGL, 430 rpm

Features

- Mounts to 2-in. coupling or flange.
- 316SS propeller folds to fit through 2-in. opening; opens to 9-in. operating diameter.
- Second folding propeller bolts anywhere on 3/4-in. shaft – part #004479.

Model Number	Standard Motor Description	Shaft Diameter
Totally-enclosed fan-cooled (TEFC)		
HGL-2.0	1/3 HP-1-115/230	3/4"
HGL-3.0	1/2 HP-1-115/230	3/4"
HGL-5.0	3/4 HP-1-115/230	3/4"
HGL-6.0	1 HP-1-115/230	3/4"
HGL-6.2	1 HP-3-230/460	3/4"
Air motor		
HGL-4.0	1/2 HP AIR Air Requirements: 20CFM at 40PSI	3/4"
HGL-7.0	3/4 HP to 1 HP AIR Air Requirements: 30-40CFM at 25-35PSI	3/4"

For Explosion-proof models, see price list.

Series DT, 420 rpm

Features

- Mounts to the tank or optional universal bracket.
- 316SS propeller folds to fit through 2-in. opening; opens to 9-in. operating diameter.
- 35-in. shaft length.

Model Number	Standard Motor Description	Shaft Diameter
Totally-enclosed fan-cooled (TEFC)		
DT-1.0	1/2 HP-1-115/230	1"
DT-1.2	1/2 HP-3-230/460	1"
DT-2.0	3/4 HP-1-115/230	1"
DT-2.2	3/4 HP-3-230/460	1"
DT-3.0	1 HP-3-230/460	1"
Air motor		
DT-1.4	1/2 HP AIR Air Requirements: 20CFM at 40PSI	1"
DT-3.2	3/4 HP to 1 HP AIR Air Requirements: 30-40CFM at 25-35PSI	1"

For Explosion-proof models, see price list.

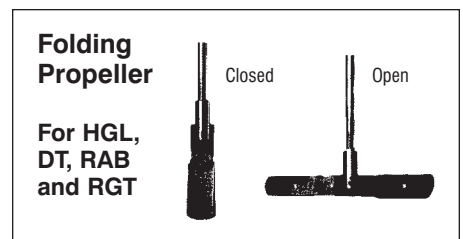

Series RAB, 350 rpm

Features

- Mounts to 2-in. coupling or flange.
- 316SS propeller folds to fit through 2-in. opening; opens to 9-in. operating diameter.
- Second folding propeller bolts anywhere on 3/4-in. shaft – part #004479.

Model Number	Standard Motor Description	Shaft Diameter
Totally-enclosed fan-cooled (TEFC)		
RAB-3.0	1/2 HP-1-115/230	3/4"
RAB-3.2	1/2 HP-3-230/460	3/4"
RAB-5.0	3/4 HP-1-115/230	3/4"
RAB-5.2	3/4 HP-3-230/460	3/4"
RAB-6.0	1 HP-1-115/230	3/4"
RAB-6.2	1 HP-3-230/460	3/4"
Air motor		
RAB-4.0	1/2 HP AIR Air Requirements: 20CFM at 40PSI	3/4"
RAB-7.0	3/4 HP to 1 HP AIR Air Requirements: 30-40CFM at 25-35PSI	3/4"

For Explosion-proof models, see price list.

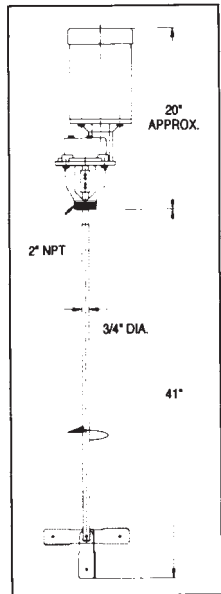

Series HGL



Series DT

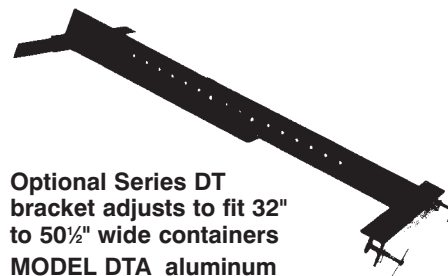
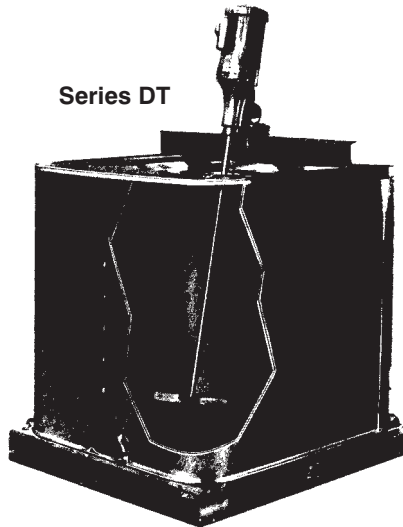

Optional Series DT bracket adjusts to fit 32" to 50 1/2" wide containers
MODEL DTA aluminum
MODEL DTS steel

Series RAB

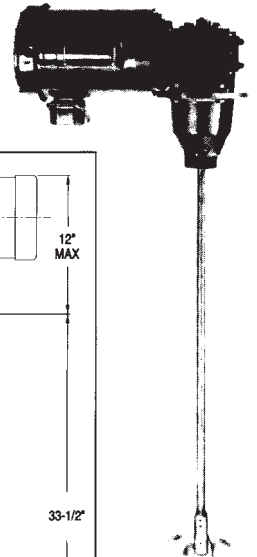
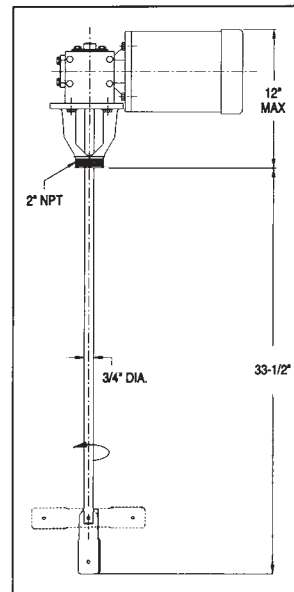

HGL Mixer ▶
with Cap Mount



Bulk Container Mixers – Gear Drive Bung or Bracket Mount Low Profile Mixers

Use on single containers or sandwich between stacked semi-bulk shipping containers.

Series RGT, 350 rpm

Features

- Mounts to the tank or optional bracket.
- 316SS propeller folds to fit through 2-in. opening; opens to 9-in. operating diameter.
- Second folding propeller bolts anywhere on 3/4-in. shaft – part #004479.

Model Number	Standard Motor Description	Shaft Diameter
Totally-enclosed fan-cooled (TEFC)		
RGT-1.0	1/2 HP-1-115/230	3/4"
RGT-1.2	1/2 HP-3-230/460	3/4"
RGT-2.0	3/4 HP-1-115/230	3/4"
RGT-2.2	3/4 HP-3-230/460	3/4"
RGT-3.0	1 HP-1-115/230	3/4"
RGT-3.2	1 HP-3-230/460	3/4"
Air motor		
RGT-1.4	1/2 HP AIR Air Requirements: 20CFM at 40PSI	3/4"
RGT-3.4	3/4 HP to 1 HP AIR Air Requirements: 30-40CFM at 25-35PSI	3/4"

For Explosion-proof models, see price list.

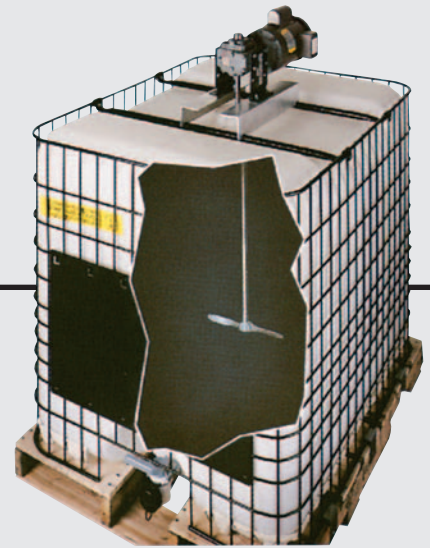
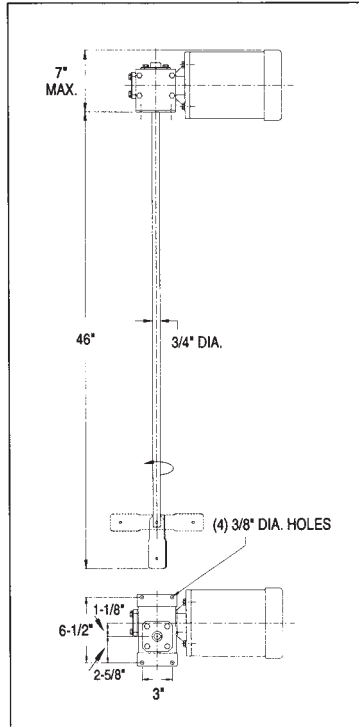

**RGT Mixer
Installed Between
Stackable IBCs**



**RGT Mixer
with Custom
Mounting Bracket**

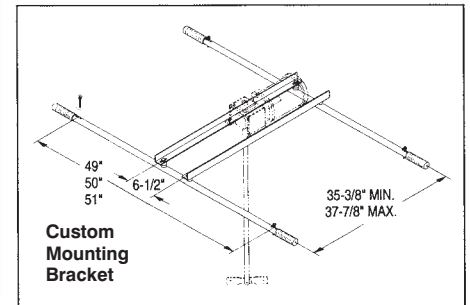
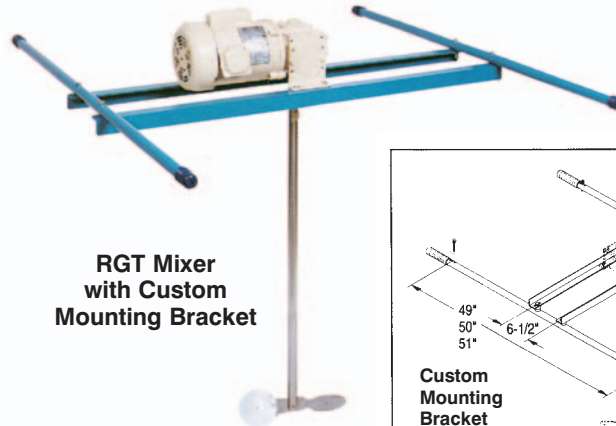

We stock custom brackets to adapt RGT mixers to the following IBCs:

- CLAWSON
- CLEAN EARTH
- HOOVER
- POLYPROCESSING
- SCHULTZ
- SNYDER
- SONOCO

**RGT Mixer
with RGT-BKT
Mounting Bracket**

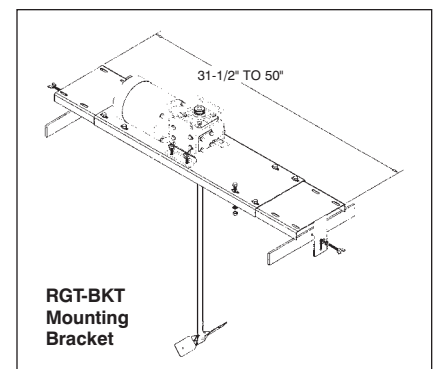
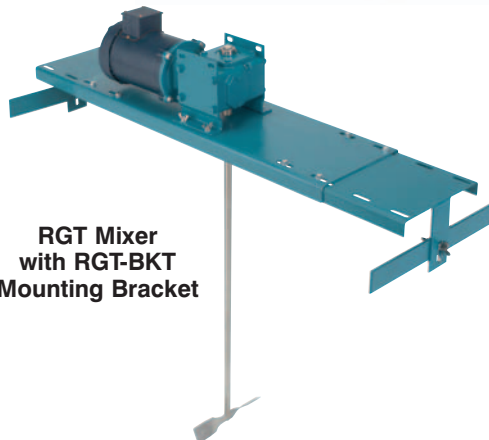

Specialty Mixers Pipe and Pail-Mount, Hand-Held

Pail Mixers – Pipe Clamp

Ideal for mixing materials in 5-gallon containers and other open containers. Mixer clamps to a vertical 1½-in. pipe which allows it to be lowered into container and raised to change containers.

Features

- Air control valve for speed adjustment.
- Folding propeller optional.



MODEL B-4.OP

Model Number	Standard Motor Description	Shaft Length	Propeller Diameter	Shaft Diameter
B-4.OP	1/4 HP to 1/2 HP AIR Air Requirements: 10-17 CFM at 50-80 PSI	24"	4" Fixed	5/8"
B-4.OP-D	Same as above except with dual propellers			

Pail Mixers – Rim Clamp

Convenient mixer for mixing materials in 5-gallon closed pails. The handle/motor assembly adjusts along the center line of the pail to align with the opening in pail lid.

Features

- Air control valve for speed adjustment on air motor model.



Model Number	Standard Motor Description	Shaft Length	Propeller Diameter	Shaft Diameter
PAM-6.0	1/2 HP to 1 HP AIR Air Requirements: 22-40 CFM at 40-80 PSI	12"	3¾" Folding	5/8"

HandleBar Pail and Drum Mixers

Popular for mixing open and closed head containers from 5 to 55 gallons. Can also be used to mix mortar, drywall compound and similar materials in 5-gallon containers.

Air control valve allows easy speed adjustment. Low speed mixing and stalling will not overheat as with an electric motor.

Optional "deadman" trigger on right handle allows mixer to be started and stopped conveniently while maintaining grip with two hands. Specify Part Number 106482.



MODEL HAJ-3.0

Model Number	Recommended Container Size/Type	Shaft Dia. and Length	Propeller Type	Propeller Size
H AJ-3.0	To 10 Gallon Open Head	½" x 21"	Caged Impeller	5"
H AJ-3.1	To 55 Gallon Open Head	½" x 40"	Caged Impeller	5"

All mixers above use air motor rated from 1/2 to 1 HP using 22 to 40 CFM air at 40 to 80 PSI.

Hand-Held Mixers

Air-driven mixers feature cast aluminum pistol grip to comfortably fit the hand.

Used to mix small batches of thin or heavy liquids. Air control valve allows easy speed adjustment. Low speed mixing and stalling in heavy liquids will not cause overheating as with an electric mixer.

Stainless steel multi-blade cage impeller will not damage container and is ideal for rapid, thorough mixing of paints, adhesives, dry wall compounds, etc. Two impeller sizes and three shaft lengths fit most open top containers from 1 to 55 gallons.

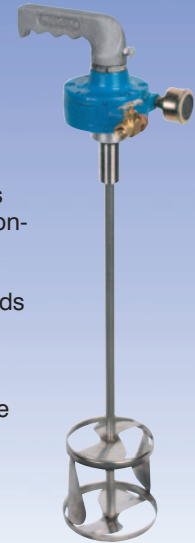

MODEL HH10

Model Number	Recommended Container Size	Shaft Dia. and Length	Mixing Head Diameter
HH12	1 to 2 Gallon	¼" x 15"	2½"
HH10	5 to 10 Gallon	½" x 21"	5"
HH55	50/55 Gallon	½" x 40"	5"



SOLD BY:

standard group



Since 1986
www.pumpsuae.com

standard group of companies

Pumping Solutions Since 1986

DUBAI - ABUDHABI - MUSCAT - PUNE